

# Short Radius Elbows and Returns - ANSI B16.28

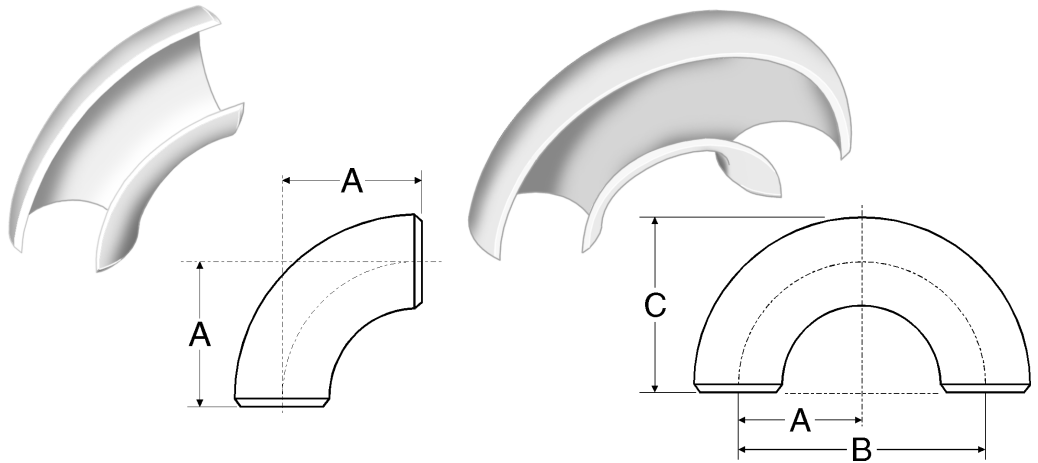

Dimensions (based on ASME/ANSI B16.28) and example weights for short radius elbows and returns

Nominal Pipe Size	Common		90° Elbow			180° Return				
	OD		Dimension A		40S/STD <sup>1</sup>	Dimension B		Dimension C		40S/STD <sup>1</sup>
	in	mm	in	mm	kg/piece	in	mm	in	mm	kg/piece
1	1.32	33	1.00	25	0.12	2.00	51	1.62	41	0.24
1 <sup>1</sup> / <sub>4</sub>	1.66	42	1.25	32	0.20	2.50	64	2.06	52	0.40
1 <sup>1</sup> / <sub>2</sub>	1.90	48	1.50	38	0.29	3.00	76	2.44	62	0.48
2	2.38	60	2.00	51	0.51	4.00	102	3.19	81	1.02
2 <sup>1</sup> / <sub>2</sub>	2.88	73	2.50	64	1.02	5.00	127	3.94	100	2.04
3	3.50	89	3.00	76	1.50	6.00	152	4.75	121	3.00
3 <sup>1</sup> / <sub>2</sub>	4.00	102	3.50	89	2.06	7.00	178	5.50	140	4.12
4	4.50	114	4.00	102	3.12	8.00	203	6.25	159	6.24
5	5.56	141	5.00	127	5.28	10.00	254	7.75	197	10.6
6	6.62	168	6.00	152	7.94	12.00	305	9.31	237	15.9
8	8.62	219	8.00	203	17.1	16.00	406	12.31	313	35.5
10	10.75	273	10.00	254	28.6	20.00	508	15.38	391	57.2
12	12.75	324	12.00	305	36.3	24.00	610	18.38	467	72.6
14	14.00	356	14.00	356	45.8	28.00	711	21.00	533	91.6
16	16.00	406	16.00	406	59.4	32.00	813	24.00	610	118.8
18	18.00	457	18.00	457	79.4	36.00	914	27.00	686	158.8
20	20.00	508	20.00	508	97.5	40.00	1016	30.00	762	195
22	22.00	559	22.00	559	-	44.00	1118	33.00	838	-
24	24.00	610	24.00	610	137	48.00	1219	36.00	914	274
26 - 48	Short radius returns are not specified for these pipe sizes									

Notes

- Dimension A = One half of dimension B
- Dimensions quoted in mm are 'Nominal' values from B16.28 (i.e. rounded equivalents of the inch dimensions). Refer to B16.28 for additional 'Max' and 'Min' metric dimensions.
- For tolerances see page 6-2.
- 1 Weights are approximate and based on manufacturers' data (where available) for Schedule 40S/Standard fittings. See page 6-6 for further information.